

SPEED SHORE

MANUFACTURER'S TABULATED DATA

TUFF-LITE™ 3"

TUFF-LITE™ 4"

TUFF-LITE™ 6"

STEEL TRENCH SHIELDS

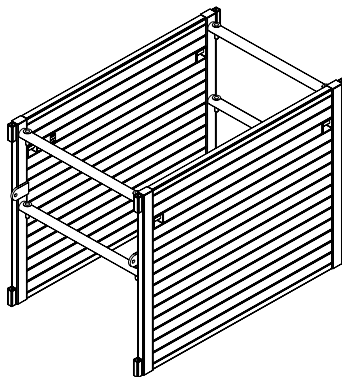

February 1, 2004

SPEED  **SHORE**

3330 S. SAM HOUSTON PKWY E. HOUSTON, TEXAS 77047
Tel: (713) 943-0750 U.S.A. Toll Free: (800) 231-6662 Fax: (713) 943-8483

COPYRIGHT, U.S.A., SPEED SHORE CORPORATION, 2003

WARNING

EXCAVATION PROCEDURES MAY BE VERY DANGEROUS

- **A TRAINED *COMPETENT PERSON* SHALL: SUPERVISE ALL EXCAVATION OPERATIONS, ENSURE THAT ALL PERSONNEL ARE WORKING IN SAFE CONDITIONS, AND HAVE THOROUGH KNOWLEDGE OF THIS TABULATED DATA. THE *COMPETENT PERSON* SHALL HAVE THE AUTHORITY TO STOP WORK WHEN IT IS UNSAFE FOR WORKERS TO ENTER AN EXCAVATION.**
- **ALL PERSONNEL SHALL BE TRAINED IN CORRECT EXCAVATION PROCEDURES, PROPER USE OF THE PROTECTIVE SYSTEM AND ALL SAFETY PRECAUTIONS.**
- **EXCAVATIONS AND PROTECTIVE SYSTEMS SHALL BE INSPECTED AT LEAST DAILY AND WHENEVER THERE IS A CHANGE OF SOIL, WATER OR OTHER JOB SITE CONDITIONS.**
- **ALL LIFTING AND PULLING EQUIPMENT, INCLUDING CABLES, SLINGS, CHAINS, SHACKLES AND SAFETY HOOKS SHALL BE EVALUATED FOR SUITABILITY AND CAPACITY, AND SHALL BE INSPECTED FOR DAMAGE OR DEFECTS PRIOR TO USE.**
- **ALL INSTALLATION AND REMOVAL OF SHORING AND SHIELDING SHALL BE FROM ABOVE GROUND ONLY.**
- **DO NOT ALLOW PERSONNEL TO ENTER AN EXCAVATION THAT IS NOT PROPERLY SHORED, SHIELDED OR SLOPED.**
- **PERSONNEL SHALL ALWAYS WORK WITHIN THE SHORING AND SHIELDING. PERSONNEL SHALL NOT STAND ON THE EDGE OF AN UNSHORED EXCAVATION.**
- **ALL PERSONNEL SHALL ENTER AND EXIT EXCAVATIONS ONLY WITHIN SHIELDED OR SHORED AREAS.**

SPEED SHORE'S "MANUFACTURER'S TABULATED DATA" IS A GENERAL SET OF GUIDELINES AND TABLES TO ASSIST THE *COMPETENT PERSON* IN SELECTING A SAFETY SYSTEM AND THE PROPER SHORING OR SHIELDING EQUIPMENT. THE *COMPETENT PERSON* HAS SOLE RESPONSIBILITY FOR JOB SITE SAFETY AND THE PROPER SELECTION AND INSTALLATION AND REMOVAL OF THE SHORING OR SHIELDING EQUIPMENT.

THIS TABULATED DATA IS NOT INTENDED TO BE USED AS A JOB SPECIFIC EXCAVATION SAFETY PLAN, BUT SHALL BE USED BY THE *COMPETENT PERSON* TO SUPPLEMENT HIS TRAINING, HIS EXPERIENCE AND HIS KNOWLEDGE OF THE JOB CONDITIONS AND SOIL TYPE.

SPEED SHORE
TABULATED DATA

1.0 SCOPE

- 1.1 Speed Shore's Tabulated Data complies with the OSHA Excavation Standards as stated in the Code of Federal Regulations 29, Part 1926, Subpart P - Excavations, Section 1926.652(c)(2). The contractor's competent person in the selection of Speed Shore Tuff-Lite™ Shields shall only use this data. The *competent person* shall be experienced and knowledgeable in trenching and excavation procedures, soil identification and in the use of Speed Shore Tuff-Lite™ Trench Shields.
- 1.2 All personnel involved in the installation, removal and use of Tuff-Lite™ Trench Shields shall be trained in their use and advised of appropriate safety procedures.
- 1.3 Table TL3-1, TL4-1 and TL6-1 are based upon requirements stated in CFR 29, Part 1926 and applicable portions of CFR 29, Part 1910. The *competent person* shall know and understand the requirements of those standards before using this data.
- 1.4 Whenever there is a variance between this Tabulated Data and CFR 29, Part 1926, Subpart P - Excavations, this Tabulated Data shall take precedence. Whenever a topic or subject is not contained in this Tabulated Data, the *competent person* shall refer to CFR 29, Part 1926, Subpart P - Excavations.
- 1.5 This data refers to the Code of Federal Regulations, 29, Parts 1910 and 1926. Where states have their own state OSHA plan, refer to similar regulations in the current construction rules published by the state office of Occupational Health and Safety.
- 1.6 Tables TL3-1, TL4-1 and TL6-1 shall be used only in excavations with soil conditions as noted. For other soil and excavation conditions and depths, site-specific engineered designs are required. Contact Speed Shore Corporation for assistance.
- 1.7 This Tabulated Data is applicable for standard products manufactured exclusively by Speed Shore and may only be used with Speed Shore manufactured products. Any modification of Speed Shore products not specifically authorized by Speed Shore Corporation voids this tab data.

2.0 DEFINITIONS (RE: CFR 29, Part 1926.32 Definitions) - RESTATED FOR EMPHASIS

- 2.1 1926.32 (F) "*competent person*" means one who is capable of identifying existing and predictable hazards in the surroundings or working conditions which are unsanitary, hazardous or dangerous to employees; and who has authorization to take prompt corrective measures to eliminate them.
- 2.2 1926.32 (p) "Shall" means mandatory.

3.0 SOIL CLASSIFICATIONS

- 3.1 In order to use the data presented in Tables TL3-1, TL4-1, and TL6-1 the soil type, or types, in which the excavation is cut shall first be determined by the *competent person* according to the OSHA soil classifications as set forth in CFR 29, Part 1926, Subpart P, Appendix A.
- 3.2 Tables TL3-1, TL4-1, and TL6-1 also reference Type C-60 soil (see 3.3 for definition).
- 3.3 Type C-60 soil is a moist, cohesive soil or a moist dense granular soil, which does not fit into OSHA Type A or Type B classifications, and is not flowing or submerged. This material can be cut with near vertical sidewalls and will stand unsupported long enough to allow the shields to be properly installed. The *competent person* must monitor the excavation for signs of deterioration of the soil as indicated by, but not limited to, freely seeping water or flowing soil entering the excavation around or below the Trench Shield. An alternate design for less-stable Type C soil may be required where there is evidence of deterioration.

- 3.4 Water flowing into an excavation, from either above or below ground, will cause a decrease in the stability of the soil. Therefore, the *competent person* shall take action to prevent water from entering the excavation and promptly remove any water that accumulates in the excavation. Closer monitoring of the soil is required under wet conditions, particularly in the less cohesive (weaker) soil conditions. A small amount of water, or flowing conditions may downgrade the soil classification to a less stable classification. A large amount of water, or flowing conditions will downgrade all soils to OSHA. Type C. Speed Shore shoring and shielding systems may be used safely in wet conditions when the excavation is monitored by the *competent person*. Example: When repairing a leak in utility lines, it is often difficult or even impossible to keep water out of the excavation.

4.0 PRESENTATION OF INFORMATION

- 4.1 Information is presented in tabular form in Tables TL3-1, TL4-1, and TL6-1 for use in OSHA. Type A, B and C soils, and for use in Type C-60 soil (see 3.3 for definition).
- 4.2 Tables TL3-1, TL4-1, and TL6-1 is not considered adequate when loads imposed by structures or by stored material adjacent to the trench weigh in excess of the load imposed by 3 feet of soil surcharge. The term "adjacent" as used here means the area within a horizontal distance from the edge of the trench equal to the depth of the trench.
- 4.3 Using Tables TL3-1, TL4-1, and TL6-1 the *competent person* determines the maximum depth the Tuff-Lite™ Trench Shield may be used.

5.0 ASSEMBLY

- 5.1 A competent person before assembly shall inspect all Tuff-Lite™ Shields components.
- 5.2 Any damage shall be evaluated and repairs made under the direction of a registered professional engineer. All missing or damaged components shall be replaced with genuine Speed Shore parts.
- 5.3 All lifting and pulling equipment, (including cables, slings, chains, shackles and safety hooks) used to handle shields or components shall be evaluated for lifting capacity, and inspected for damage or defects, prior to use, by experienced operators and shall meet OSHA requirements.
- 5.4 Tag lines or other approved safety devices shall be utilized to keep employees away from loads handled by lifting equipment.
- 5.5 Spreaders, pins with keepers and accessories shall be in place before using the Tuff-Lite™ shields.
- 5.6 Two spreaders are required at each end of all shields.
- 5.7 All spreaders shall be pinned at each end with 1.5-inch diameter pins furnished by Speed Shore.
- 5.8 Assembly instructions:
- 5.8.1 Lay first Tuff-Lite™ panel on ground, spreader sockets up
 - 5.8.2 Stand spreaders over sockets and insert pins with keepers.
 - 5.8.3 Lower second Tuff-Lite™ panel onto spreader tubes and insert pins with keepers.
 - 5.8.4 Attach 4-point lifting sling to lifting brackets.
 - 5.8.5 Stand Tuff-Lite™ shield up, attach tag lines and install into trench properly.

6.0 INSPECTION

- 6.1 The *competent person* must evaluate the soils to assure the lateral pressure of the soil does not exceed the rated capacity of the Tuff-Lite™ Trench Shields. Soils shall be evaluated in accordance with Part 3.0.

- 6.2 The *competent person* shall monitor all phases of the assembly, installation and use of this product to evaluate and eliminate methods, which could endanger employees utilizing this product.
- 6.3 The *competent person* must perform daily inspections of the Tuff-Lite™ Trench Shields and accessories. Any deficiencies must be promptly corrected with out exposure to personnel
- 6.4 Inspections shall be conducted as necessary for hazards associated with: water accumulation, changing soil conditions, or changing site weather conditions.
- 6.5 Stacked shields shall be monitored to assure that each panel is secured to the one below it. Four feet high stacking shields (those with only 2 spreaders) shall not be used as the bottom shield.

7.0 SAFETY SPECIFICATIONS

- 7.1 Employees shall be protected from loose or falling material. Tuff-Lite™ Trench Shields must always be used in a manner that loose or falling soil cannot enter over the top or through the end of the shield. End protection may be required. Spoil piles must be kept back from the edge of the excavation at least 2 feet.
- 7.2 Employees shall not enter or exit shields through unprotected areas and shall remain in shields at all times while working.
- 7.3 Employees shall not be in or under a shield while it is being lifted or moved.
- 7.4 Bottom of shields may be a maximum of 2 feet above the bottom of the trench if there are no signs of deterioration of the trench face below or at the end of the shield.
- 7.5 Use of the spreader system for any purpose other than support for the sidewall panels, or for pulling them forward is prohibited without written permission from the manufacturer.
- 7.6 The sides of the excavation should be cut vertical and narrow to prevent lateral movement of the shield. The width of the excavation shall be no wider than the width of the shield plus 12 inches.
- 7.7 Only use Speed Shore supplied standard spreaders.
- 7.8 Water shall be prevented from entering the excavation and any water that does accumulate in the excavation shall be pumped out.
- 7.9 Contact Speed Shore for any non-typical use of the Tuff-Lite™ Trench Shield.

8.0 EXAMPLE TO ILLUSTRATE THE USE OF TABLE TL3-1:

Problem: A trench is 8 feet deep in soil that has been classified by the *competent person* to be OSHA. Type B. For pipe joint purposes, 12 feet long shields are required. Which Tuff-Lite™ Trench Shields may be used?

Studying Table TL3-1 shows that a TS-812TL3 is adequate down to 25 feet.

TABLE TL3-1

MODEL	CAPACITY P.S.F.	MAXIMUM DEPTH RATING FOR SPOIL TYPE FEET				VERTICAL PIPE CLEARANCE INCHES	WEIGHT APPX. POUNDS
		A-25	B-45	C-60	C-80		
TS-0406TL3	5,288	50	50	50	50	24	1,286
TS-0408TL3	2,889	50	50	49	37	24	1,567
TS-0410TL3	1,817	50	41	31	24	24	1,848
TS-0412TL3	1,248	49	28	22	17	24	2,128
TS-0414TL3	909	35	21	16	12	24	2,409
TS-0606TL3	3,520	50	50	50	46	36	1,765
TS-0608TL3	2,602	50	50	45	35	36	2,157
TS-0610TL3	1,741	50	40	31	24	36	2,549
TS-0612TL3	1,195	48	28	22	17	36	2,941
TS-0614TL3	871	35	21	16	13	36	3,333
TS-0806TL3	2,064	50	48	37	29	36	2,214
TS-0808TL3	1,526	50	36	28	22	48	2,716
TS-0810TL3	1,210	50	29	23	18	48	3,220
TS-0812TL3	1,003	41	25	20	16	48	3,722
TS-0814TL3	852	35	21	17	14	48	4,226

Notes:

- (1) If a specific model TL3 trench shield is not shown in Table TL3-1, the competent person must refer to the trench shield certification to determine capacity and working depths. All other aspects of this tabulated data applies to any TL3 shield not shown in Table TL3-1.
- (2) Weights are approximate.
- (3) Standard spreader sizes for TL3 shields are 5” schedule 80 pipes, maximum length of 12’. Spreader materials shall conform to ASTM A501 or ASTM A53, Type E or S, grade B.

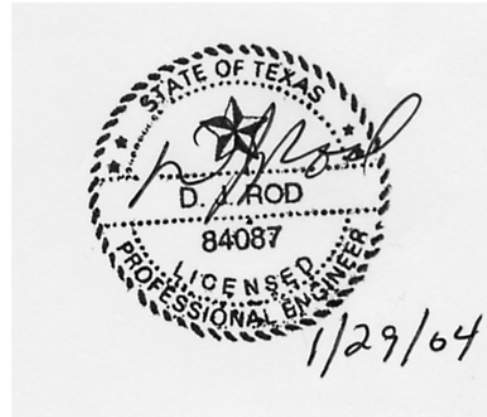

TABLE TL4-1

MODEL	CAPACITY P.S.F.	MAXIMUM DEPTH RATING FOR SPOIL TYPE (FEET)				VERTICAL PIPE CLEARANCE INCHES	WEIGHT APPX POUNDS
		A-25	B-45	C-60	C-80		
TS-0406TL4	8,441	50	50	50	50	24	1,540
TS-0408TL4	4,708	50	50	50	50	24	1,870
TS-0410TL4	2,920	50	50	49	38	24	2,180
TS-0412TL4	1,987	50	45	34	26	24	2,470
TS-0414TL4	1,439	50	32	25	19	24	2,790
TS-0416TL4	1,090	43	25	19	15	24	3,160
TS-0420TL4	687	27	16	12	10	24	3,775
TS-0606TL4	4,822	50	50	50	50	36	2,010
TS-0608TL4	3,522	50	50	50	46	36	2,425
TS-0610LT4	2,717	50	50	47	36	36	2,790
TS-0612TL4	1,848	50	42	33	25	36	3,205
TS-0614TL4	1,338	50	31	24	19	36	3,615
TS-0616TL4	1,014	41	24	19	15	36	4,190
TS-0620TL4	639	26	16	12	10	36	4,540
TS-0806TL4	3,228	50	50	50	43	48	2,290
TS-0808TL4	2,357	50	50	42	33	48	3,050
TS-0810TL4	1,857	50	44	34	26	48	3,580
TS-0812TL4	1,531	50	36	28	22	48	4,130
TS-0814TL4	1,288	50	31	24	19	48	4,750
TS-0816TL4	975	40	24	19	15	48	5,230
TS-0820TL4	615	26	16	13	11	48	6,290

Notes:

- (4) If a specific model TL4 trench shield is not shown in Table TL4-1, the competent person must refer to the trench shield certification to determine capacity and working depths. All other aspects of this tabulated data applies to any TL4 shield not shown in Tables TL4-1.
- (5) Weights are approximate.
- (6) Standard spreader sizes for TL4 shields are 5" schedule 80 pipes, maximum length of 12'. Spreader materials shall conform to ASTM A501 or ASTM A53, Type E or S, grade B.

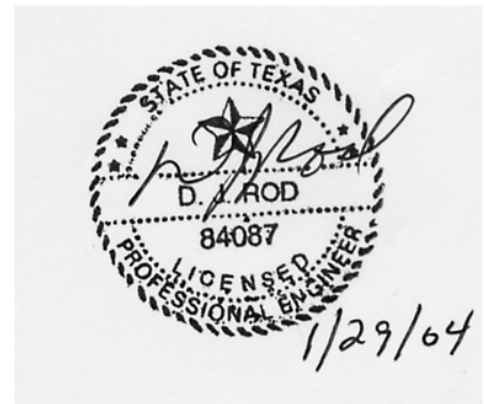

TABLE TL6-1

MODEL	CAPACITY P.S.F.	MAXIMUM DEPTH RATING FOR SPOIL TYPE (FEET)				VERTICAL PIPE CLEARANCE INCHES	WEIGHT APPX. POUNDS
		A-25	B-45	C-60	C-80		
TS-0412TL6	4,321	50	50	50	50	20	3,813
TS-0416TL6	2,352	50	50	40	31	20	4,825
TS-0420TL6	1,476	50	33	25	20	20	5,836
TS-0424TL6	1,012	40	23	18	14	20	6,848
TS-0428TL6	737	29	17	13	10	20	7,860
TS-0612TL6	4,096	50	50	50	50	42	5,000
TS-0616TL6	2,229	50	50	39	30	42	6,356
TS-0620TL6	1,399	50	32	25	20	42	7,711
TS-0624TL6	959	38	23	18	14	42	9,067
TS-0628TL6	698	28	17	13	11	42	10,423
TS-0812TL6	2,479	50	50	44	34	65	6,275
TS-0816TL6	1,732	50	41	32	25	65	7,974
TS-0820TL6	1,361	50	33	25	20	65	9,673
TS-0824TL6	933	38	23	18	15	65	11,373
TS-0828TL6	679	28	17	14	12	65	13,070

Notes

- (7) If a specific model TL6 trench shield is not shown in Table TL6-1, the competent person must refer to the trench shield certification to determine capacity and working depths. All other aspects of this tabulated data applies to any TL6 shield not shown in Table TL6-1.
- (8) Weights are approximate.
- (9) Standard spreader sizes for TL6 shields are 8" schedule 80 pipes, maximum length of 20'. Spreader materials shall conform to ASTM A501 or ASTM A53, Type E or S, grade B.

